

2x32 Rackmount GNSS Splitter

DESCRIPTION

The RMS232 amplifies and splits the GPS/GNSS signal. It includes dual input ports and 32 output ports. The dual input ports connect two GPS receive antennas. The output ports grant up to 32 GPS/GNSS receivers signal access at one time.

Typically, the RMS232 is configured with an 110VAC input (-48V telecom power input also available) and a regulated DC output voltage that is passed to the antenna input ports in order to power an active GPS antenna on that port. In this scenario, the RF outputs (OUT1 – OUT32) would feature a 200 Ohm DC load to simulate an antenna DC current draw for any receiver connected to those ports.

Redundancy is acquired through the use of a primary antenna and a backup antenna. The ability of the RMS232 to switch antennas allows all connected GPS devices to remain fully functional in the event of an antenna failure. Faults are indicated on the front panel LED and status via a DB9 interface.

Within the RMS232 is an antenna health sensor and an embedded antenna switch. The sensor monitors the health of the primary antenna connected to the splitter. Based on the information provided by the sensor, the splitter will switch to the secondary antenna in the event of a failure with the primary antenna.

If the failure in the primary antenna is resolved, the splitter will automatically switch back to the primary. The embedded switch has been designed so it can be controlled externally via an external rocker switch that can override the internal automatic switch mechanism.

The dual power supply option allows two internal power supply units to share the load. If one unit is not available (internally or externally), the other will seamlessly take over without any loss in power. The fault will be indicated on the front panel LED and status via a DB9 interface.



FEATURES

- 32 GPS/GNSS Output Ports
- -48VDC Power Supply Option
- Embedded Antenna Health Sensor
- Automatic Internal Antenna Port Switch
- External Antenna Port Switching Capability
- Passes GPS L1/L2, GLONASS L1/L2, Galileo, Compass
- Antenna Fault Indicator Panel
- Dual Power Option

OPTIONS

The RMS232 splitter comes with many available options to meet specific needs. Please contact GPS Source via phone, fax, email, or visit the website for further information on product options and specifications.

RMS232 Data Sheet

059-FSA-AFS-ABX-BBZ-004

05/06/2016

www.gpssource.com

1. RMS232 Specifications

1.1 Electrical Specifications

Table 1-1. Operating Temperature -40°C to 85°C

Parameter		Conditions	Min	Typ	Max	Units
Frequency Range		Ant: Any Port; Unused Ports: 50Ω	1.2		1.65	GHz
Gain	Amplified (Normal)	Ant: Any Port; Unused Ports: 50Ω	2	4	6	dB
	Amplified (Custom) ⁽¹⁾	As Specified (xdB, 0 to 16dB)	X - 2	X	X + 2	dB
In/Out Imped.		Ant, OUT1-OUT32		50		Ω
Input SWR		All Ports 50Ω			2:1	—
Output SWR		All Ports 50Ω			2:1	—
Noise Figure		Ant: Any Port; Unused Ports: 50Ω, Gain = 4dB			5	dB
Gain Flatness		L1 – L2 Ant: Any Port; Unused Ports: 50Ω			3	dB
Amp. Balance		J3 - J4 , [J1, J2] Ant: Any Port; Unused Ports: 50Ω			3	dB
Phase Balance		Phase (J3-J4), Ant (J1, J2) - Any Port; Unused Ports: 50Ω			1	Degree
Group Delay Flatness		Td, max - Td, min, Ant - Any Port			1	ns
Isolation	Amp (Hi Iso.) (Gain = 0dB)	Measured at 1227MHz and 1575MHz	38			dB
		Opposite Ports: Ant – 50Ω Adjacent Ports: Ant – 50Ω	24			
Output I_{P3} (Amplified)		Ant: Any Port; Unused Ports 50Ω, Gain = 4dB, Tone Spacing = 1MHz	-7			dBm
Output P_{1dB} (Amplified)		Ant: Any Port; Unused Ports 50Ω, Gain = 4dB	-16			dBm
AC IN	110/220/240	Wall Mount Transformer (Various international plug types available)	110		240	VAC
DC IN	DC Blk	All output ports blocked with a 200Ω Load			14	VDC
		Powered, Mil. Conn. with leads option	12		16	
		Powered, Mil. Conn. ⁽²⁾ with leads option	+20 -20	+48 +48		VDC
Current (I_{internal})		Current Consumption of device (excludes Ant. Cur.)			180	mA
Ant/Thru Current	Powered	Input Port			100	mA
Max RF Input	Amplified	Max RF Input Without Damage			20	dBm

- Notes: 1. Custom gain options available, gain will be the same for all outputs
2. Supports -48VDC power supply

1.2 Antenna Control Specifications

Antenna control can be automatic with manual override.

1.2.1 Automatic Control

(Default Option) — The automatic control will automatically select the primary or alternate antenna based on the fault status of the two antennas. The fault status is determined by the current draw of the antennas. A current draw below 12.5mA and above 120mA will signal a fault for the respective input port. The fault condition will cause the device to automatically switch to the other input port. The fault status is displayed on the front panel. The antenna status is indicated via the DB9.

1.2.2 Antenna Control

The secondary antenna is manually selected by activating an illuminated rocker switch on the front panel.

1.3 Antenna Power Fault

The antenna and power status is available to an external application via a set of signals in the DB9 connector. The signals enable the external application to identify antenna faults at J1 and J2 or a faulty power input. The fault status is output via a SPDT relay. The relay is energized when unit is powered and no fault is present. The relay will be deenergized when a fault is present or when power is off. An available factory option, reverses the energized position.

The relay can switch up to 100mA at up to 60VDC or 60VAC. The normally open contact, the normally closed contact, and the common are brought out in the rear panel DB9 connector.

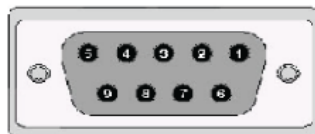

DB9(F) Pinout

Pin #	No Fault	Fault
Pin 6	Shorted to pin 7	Open to pin 7
Pin 8	Open to pin 7	Shorted to pin 7

1.4 Fault Panel Indicator

1.4.1 Single Power Option

The fault panel indicator on the face plate of the RMS232 displays antenna faults at J1 and J2. If a fault exists at either of the input ports, the "FAULT" message along with "J1" or "J2" is displayed.

1.4.2 Dual Power Option

The fault panel indicator on the face plate of the RMS232 displays antenna faults at J1 and J2. If a fault exists at either of the input ports, the "FAULT" message along with "J1" or "J2" is displayed.

In addition, a simple "Fault" message will be displayed if one of the two internal power supplies fail or if one of the two power sources (at input) fail.

2. Performance Data

2.1 RMS232 — Active Hi Isolation

Figure 2-1. Active Hi Isolation RMS232 Splitter: Gain vs. Frequency

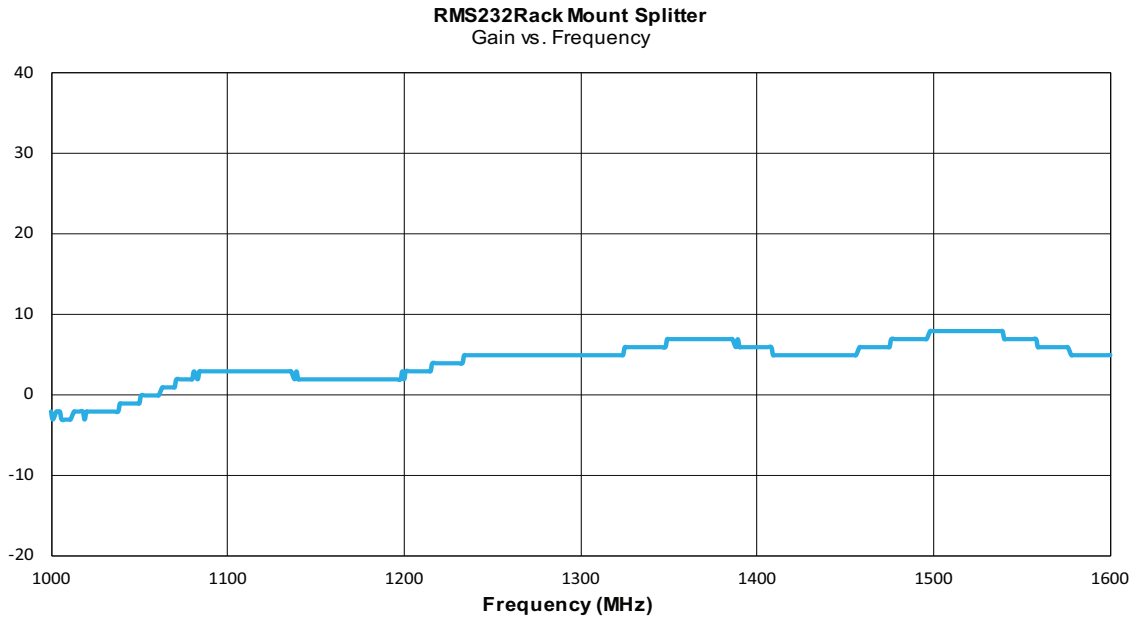
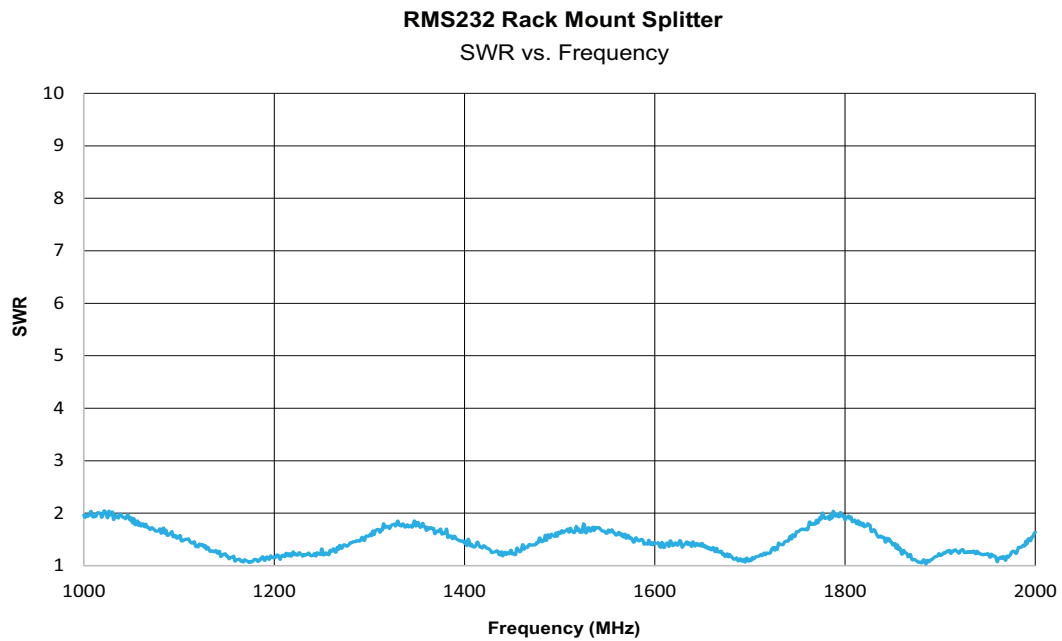

Figure 2-2. Active Hi Isolation RMS232 Splitter: SWR vs. Frequency



3. Product Options

Table 3-1. RMS232 Available Options

Power Supply		
Source Voltage Options	Voltage Input	Type
	110 VAC	Wall Mount Transformer
	220 VAC	Wall Mount Transformer
	240 VAC (U.K.)	Wall Mount Transformer
	±20V to ±50V	Military Style Connector
Output Voltage	DC Voltage Out	
	5.0	
Connector	Connector Type	Limitations
	N (Female/Male)	N/A
	SMA (Female/Male)	N/A
	TNC (Female/Male)	N/A
Housing		
Housings	Housing Type	Limitations
	19 x 13.2 x 5.3 in Rack Mount	None
Port Options		
DC Blocked	OUT1 thru OUT32 are DC Blocked and 200Ω Loaded, DC is passed to J1 (ANT 1) & J2 (ANT2)	

Table 3-2.

Power Supply Option				
Config.	Pin	Description		2 Pin Cylindrical Connector
Single Power Supply, Single Input (Standard)	A	Positive		
	B	Ground		
Config.	Pin	Description		6 pin Cylindrical Connector
Dual Power Supply, Dual Input (Option)	A	Positive	Supply 1	
	B	Ground		
	C	Positive	Supply 2	
	D	Ground		

4. Product Code Decoder

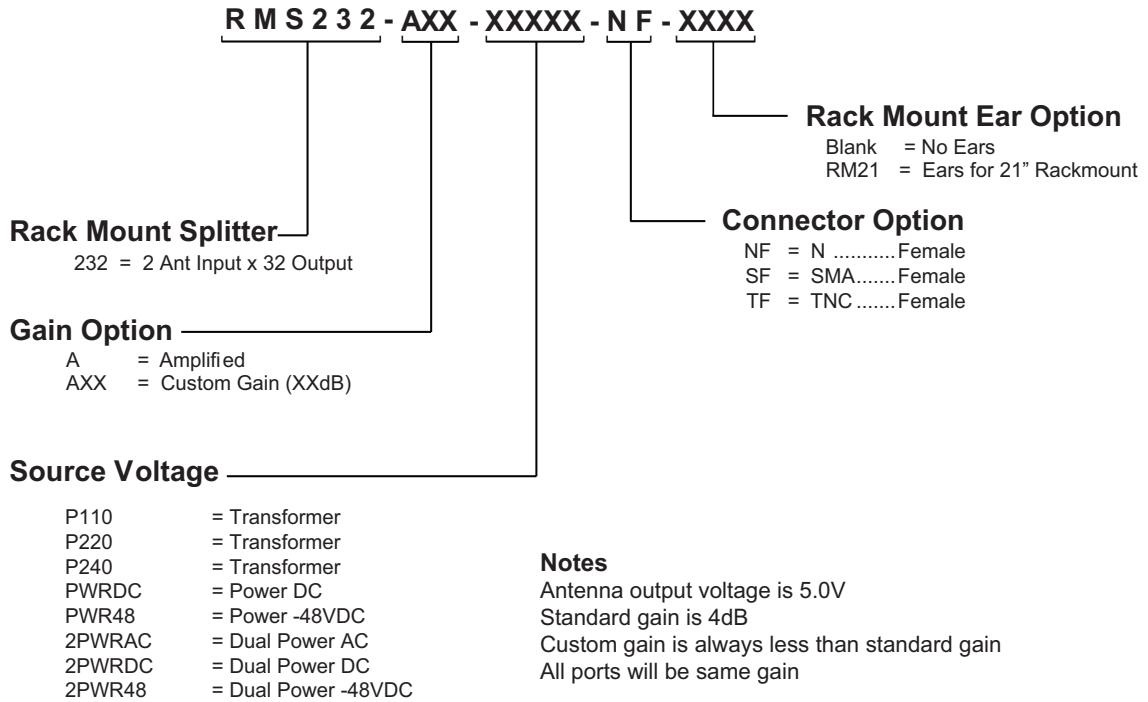

Note: To have product/part codes customized to meet exact needs, contact GPS Source at wireless@gpssource.com or visit the website at www.gpssource.com.

5. Mechanical Drawing

RMS232 — FSA-AJQ-AAX-KBZ

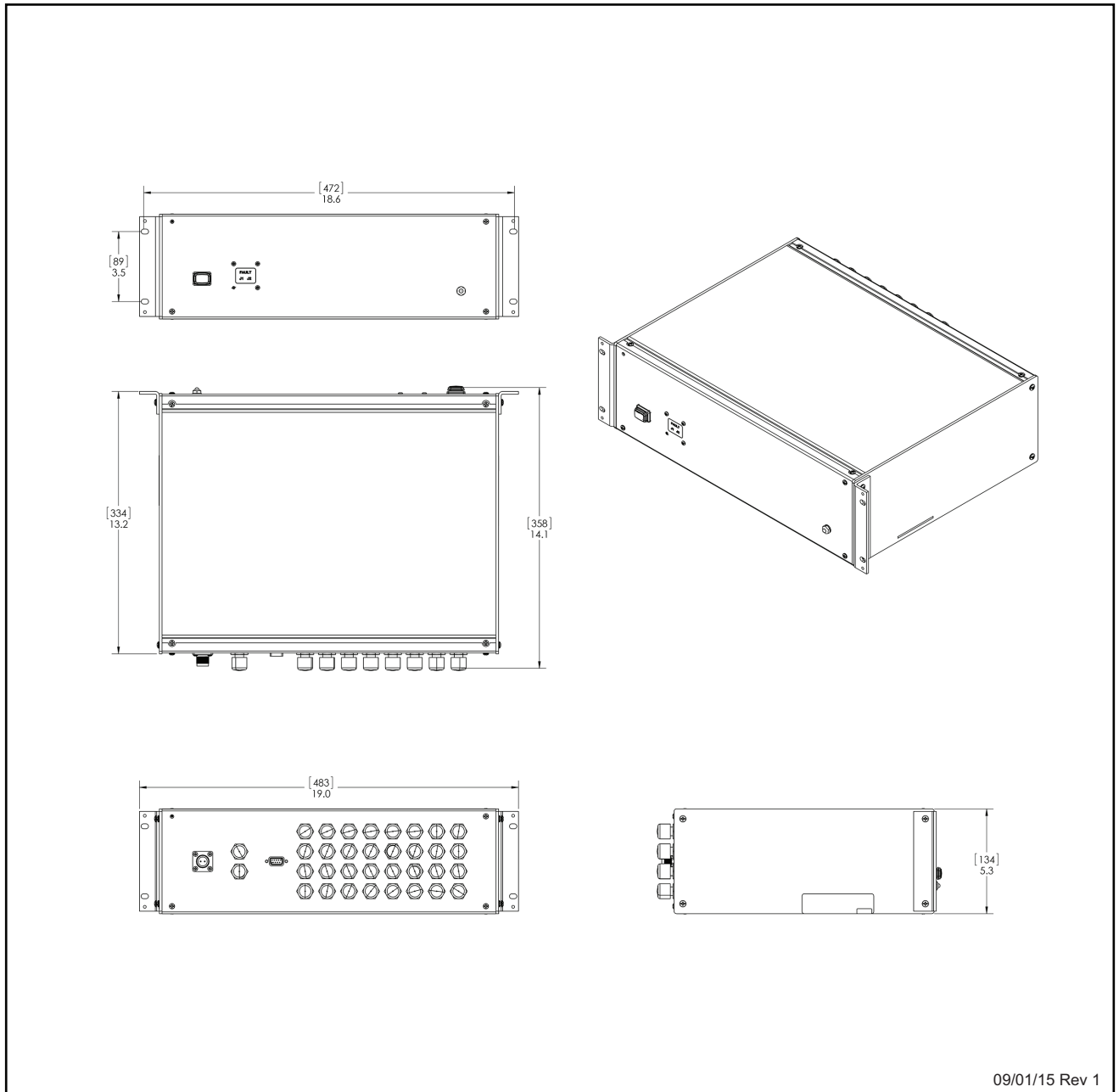

09/01/15 Rev 1

GPS Source Part No. RMS232	Finish Black	Size D	Mass 14.5lb	Tolerances	
Description RACKMOUNT 2X32 SPLTR, ANT 2 In 32 Out	Material N/A	3 rd Angle Projection 		Linear .X = ± 0.100 .XX = ± 0.010 .XXX = ± 0.005	Angular $\pm 1^\circ$ RADII See Linear
All materials and finishes shall comply with European Union RoHS and are lead free. Dimensions are in inches unless otherwise specified.					



RMS232 Data Sheet

059-FSA-AFS-ABX-BBZ-004

Page 9 of 9, 05/06/2016

64 N. Mission Drive
Pueblo West, CO 81007
Phone: (+1)(719) 561.9520
Fax: (+1)(719) 565.0890
wireless@gpssource.com
www.gpssource.com

AS9100C:2009 and ISO 9001:2008 Compliant Company



© 2013 GPS Source, Inc. All rights reserved.

GPS Source, Inc., GPS Live Inside, GPS Source logo, and other GPS Source, Inc. products, brands, and trademarks mentioned in this document are property of GPS Source, Inc. and/or its affiliates in the United States and/or other countries. Other products, brands, and trademarks are property of their respective owners/companies. Any rights not expressly granted herein are reserved.

DISCLAIMER: The materials in this document could include inaccuracies or typographical errors and are subject to change at any time. The materials are provided "as is" without warranty of any kind. To the maximum extent permitted by applicable law, GPS Source, Inc. and its suppliers hereby disclaim all warranties, either expressed or implied, and conditions with respect to the materials, their quality, performance, suitability, merchantability, fitness for a particular purpose, title, and non-infringement. LIMITATION OF LIABILITY: IN NO EVENT WILL GPS SOURCE, INC. AND ITS SUPPLIERS BE LIABLE FOR INDIRECT, SPECIAL, INCIDENTAL, OR CONSEQUENTIAL DAMAGES, WHETHER IN AN ACTION OF CONTRACT OR TORT, ARISING OUT OF THE USE OR INABILITY TO USE THE MATERIALS AVAILABLE IN THIS DOCUMENT, EVEN IF ADVISED OF THE POSSIBILITY OF SUCH DAMAGES. IN PARTICULAR AND WITHOUT LIMITATION, GPS SOURCE, INC. SHALL HAVE NO LIABILITY FOR ANY LOSS OF USE, DATA, INCLUDING THE COSTS OF RECOVERING SUCH DATA, OR PROFITS.